

Powerdrive

Product family

EN Installation and service instructions

192477-01



Contents

1	Introduction.....	3
1.1	Symbols and illustrations	3
1.2	Revisions and validity.....	3
1.3	Product liability	3
1.4	Reference documents.....	3
2	Fundamental safety notes.....	4
2.1	Intended use.....	4
2.2	Safety notes	4
2.3	Safety-conscious working	5
2.4	Environmentally conscious working.....	5
2.5	Safety notes related to transportation and storage.....	5
2.6	Qualification	5
3	About this document.....	6
3.1	Overview.....	6
4	Overview.....	7
4.1	Diagrams.....	7
4.2	Tools and aids.....	7
4.3	Torques	8
4.4	Components and assembly groups.....	8
5	Installation.....	8
5.1	Preparations to be made on-site	8
5.2	Mounting the track	8
5.3	Mounting the floor guide	9
5.4	Installing the moving leaf.....	10
5.5	Mounting the drive components	16
5.6	Installing cable guides.....	19
5.7	Connecting the tooth belt locking mechanism (optional) and control unit.....	20
5.8	Connecting the transformer ground	20
6	Production test and commissioning.....	21
6.1	Connecting the drive	21
6.2	Mounting the cover	22
6.3	Mounting the safety devices.....	24
6.4	Installing operating elements/switches/push buttons.....	24
6.5	Commissioning the door system.....	24
6.6	Dismantling	24
7	Service and maintenance	25
7.1	Mechanical service	25
7.2	Maintenance.....	25
8	Troubleshooting.....	27
8.1	Mechanical faults.....	27
8.2	Electrical faults.....	29
9	Drive type plate.....	30
10	Inspection of the installed door system	31
10.1	Measures to prevent and secure hazardous areas.....	31
10.2	Assembly check list Powerdrive product family.....	31



1 Introduction

1.1 Symbols and illustrations

Warning notices



In these instructions, warning notices are used to warn against material damage and injuries.

- ▶ Always read and observe these warning notices.
- ▶ Observe all measures marked with the warning symbol and warning word.

Warning symbol	Warning word	Meaning
	DANGER	Danger to persons. Non-compliance will result in death or serious injuries.
	WARNING	Danger to persons. Non-compliance can result in death or serious injuries.
	CAUTION	Danger to persons. Non-compliance can result in minor injuries.

Further symbols and illustrations

Important information and technical notes are highlighted to explain correct operation.

Symbol	Meaning
	means "important note". Information to prevent property damage, to understand or optimise the operation sequences.
	means "additional Information"
▶	Symbol for an action: This means you have to do something. ▶ If there are several actions to be taken, keep to the given order.

1.2 Revisions and validity

Version 01: valid for Powerdrive product family from model year 2021

1.3 Product liability

In compliance with the liability of the manufacturer for his products as defined in the German "Product Liability Act", compliance with the information contained in this brochure (product information and intended use, misuse, product performance, product maintenance, obligations to provide information and instructions) must be ensured. Failure to comply releases the manufacturer from his statutory liability.

1.4 Reference documents

Type	Name
Wiring diagram	Automatic sliding doors DCU1-NT/DCU1-2M-NT
Additional wiring diagrams	Automatic sliding doors DCU1-2M-NT, door controller DCU1-2M-NT for automatic sliding doors in escape routes, FR variants DUO, LL, RWS
User manual	Automatic sliding door systems
Faults and corrective measures	DCU1-NT/DCU1-2M-NT Drive electronics for automatic sliding doors
Cable plan	Automatic sliding door systems
Safety analysis	Automatic sliding doors
Pre-installation instructions	Powerdrive product family

These documents are subject to change. Use only the most recent version.

2 Fundamental safety notes



GEZE GmbH is referred to as GEZE below.

2.1 Intended use

The sliding door system is used for the automatic opening and closing of a building passage.

The sliding door system may only be used in a vertical installation position and in dry rooms within the permitted application area.

The sliding door system is designed for pedestrian traffic in buildings.

The sliding door system is not designed for the following uses:

- for industrial use
- for area of application which do not serve pedestrian traffic (such as garage doors)
- on mobile objects such as ships

The sliding door system may only be used:

- in the modes of operation provided for by GEZE
- with the components approved / released by GEZE
- with the software delivered by GEZE
- in the installation variants / types of installation documented by GEZE
- within the tested/approved area of application (climate / temperature / IP rating)

Any other use is considered non-intended and will lead to the exclusion of all liability and warranty claims to GEZE.

2.2 Safety notes

- Intervention and modifications which influence the safety technology and functionality of the sliding door system may only be carried out by GEZE.
- Problem-free and safe operation assumes proper transportation, proper set-up and installation, qualified operation and correct maintenance have taken place.
- The relevant accident prevention regulations and other generally recognised safety technology or health & safety rules must be kept.
- Only original accessories, original spare parts and accessories approved by GEZE guarantee problem-free function of the sliding door system
- The mandatory installation, maintenance and repair work must be performed by properly trained personnel authorised by GEZE.
- The country-specific laws and regulations are to be observed during safety technology tests.
- If unauthorised changes are made to the system, GEZE cannot be held liable in any way whatsoever for any resulting damage, and the statement of approval for use in escape and rescue routes is no longer valid.
- GEZE does not accept any warranty for combinations with third-party products.
- Only original GEZE parts may be used for repair and maintenance work.
- The connection to the mains voltage must be completed by an electrician or specialised electrical technician. Perform the power connection and protective earth connection test in accordance with VDE 0100 Part 600.
- Use an on-site 10-A overload cut-out as the line-side disconnecting device.
- Protect the display programme switch against unauthorised access.
- In compliance with Machinery Directive 2006/42/EC, a risk analysis must be performed and the door system identified in accordance with CE Marking Directive 93/68/EEC before the door system is commissioned.
- Observe the latest versions of guidelines, standards and country-specific regulations, in particular:
 - DIN 18650: "Building hardware – Powered automatic doors"
 - VDE 0100, Part 600: "Installation of low-voltage systems"
 - EN 16005: "Power operated pedestrian doorsets – Safety in use– Requirements and test methods"
 - EN 60335-1: "Household and similar electrical appliances - Safety Part 1: General requirements"
 - EN 60335-2-103: "Household and similar electrical appliances - Safety: Special requirements for drives for gates, doors and windows"
- A relevant regulation must be used to select appropriate fastening materials, such as the guidelines for planning and carrying out installation of windows and front doors for new constructions and renovations of the RAL-Gütergemeinschaft Fenster und Haustüren e.V.
- Do not loosen screw-fitted , electrical ground connections.



The product should be installed or incorporated in such a way that effortless access to the product is guaranteed during any repairs and/or maintenance, and that any removal costs do not stand out of economic proportion to the value of the product.

2.3 Safety-conscious working

- Secure workplace against unauthorised entry.
- Watch the swivelling range of long system parts.
- Never carry out work with a high safety risk (e.g. installing the drive, cover or door leaf) while alone.
- Secure the cover/drive panels against falling.
- Secure non-fixed components to prevent them falling.
- Use only the cables specified on the cable plan provided. Cables must be shielded in compliance with the wiring diagram.
- Secure loose, internal drive cables with cable ties.
- Before working on the electrical system:
 - Disconnect the drive from the 230 V mains and secure it against being switched back on again. Check isolation from power supply.
 - Disconnect the control unit from the 24 V rechargeable battery.
- Note that if an Uninterruptible Power Supply (UPS) is used, the system will still be supplied with voltage despite the fact that the power supply is disconnected.
- Always use insulated wire-end ferrules for wire cores.
- Make sure of sufficient lighting.
- Use safety glass.
- Attach safety stickers to glass door leaves.
- Risk of injury with opened drive. Hair, clothing, cables, etc. can be drawn in by rotating parts.
- Risk of injury by trapping, knocking, shearing and hair etc. being pulled in at unsecured points.
- Risk of injury due to glass breakage. Always only use safety glass.
- Risk of injury due to sharp edges on the drive and door leaf.
- Risk of injury during installation through freely moving parts.

2.4 Environmentally conscious working

- When disposing of the door system, separate the different materials and have them recycled.
- Do not dispose of batteries and rechargeable batteries with household waste.
- Comply with the statutory regulations when disposing of the door system and the batteries/rechargeable batteries.

2.5 Safety notes related to transportation and storage

- The door system and its parts are not built for hard impacts or for falling from a height.
 - ▶ Do not throw, do not drop.
- Storage temperatures under $-30\text{ }^{\circ}\text{C}$ and above $+60\text{ }^{\circ}\text{C}$ can result in damage to the device.
- Protect against humidity.
- Use special glass transport devices (e.g. A-frames) for transporting glass.
- Separate several panes on a frame or during storage using intermediate layers (e.g. cork pads, paper or plastic cords).
- Always store glass in a vertical position on level and load-bearing ground. Use suitable material as a support (e.g. wooden slats).
- In the case of insulated glass, make sure that it is placed flush across the entire element thickness on at least 2 supports.
- During storage and support, safety devices must not cause any damage to the glass or edge seal of insulated glass and must be attached flat on the pane surface.
- Dry, well ventilated, closed, weather-proof and UV-protected rooms are suitable as storage areas

2.6 Qualification

Observe country-specific regulations!

Applicable in Germany:

Companies that carry out the pre-assembly of sliding door drives for escape routes must be licensed as an expanded manufacturing facility by the testing institution that issued the type approval certificate.

3 About this document

3.1 Overview

These instructions describe the installation of the Powerdrive product family automatic sliding door systems without fixed panel.



The following drawings illustrate installation with ISO profile systems.

The following profiles can also be used in combination with the Powerdrive product family:

- Toughened safety glass clamping fitting
- Wooden moving leaf
- Framed moving leaf door

View from the front

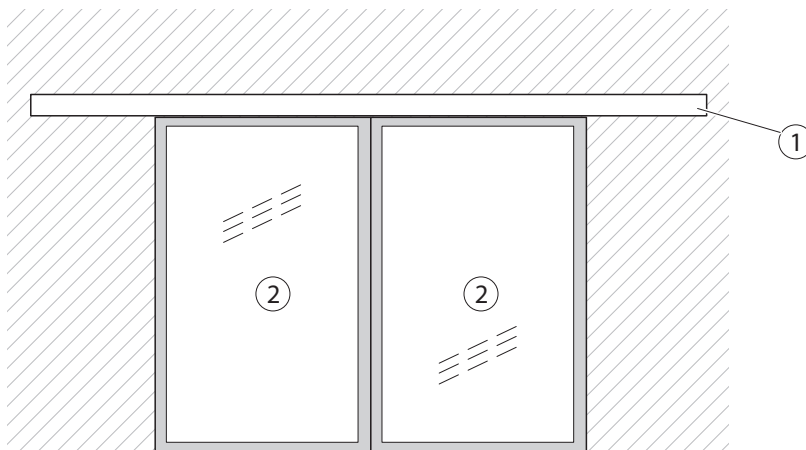

View from above (Powerdrive with ISO profiles)

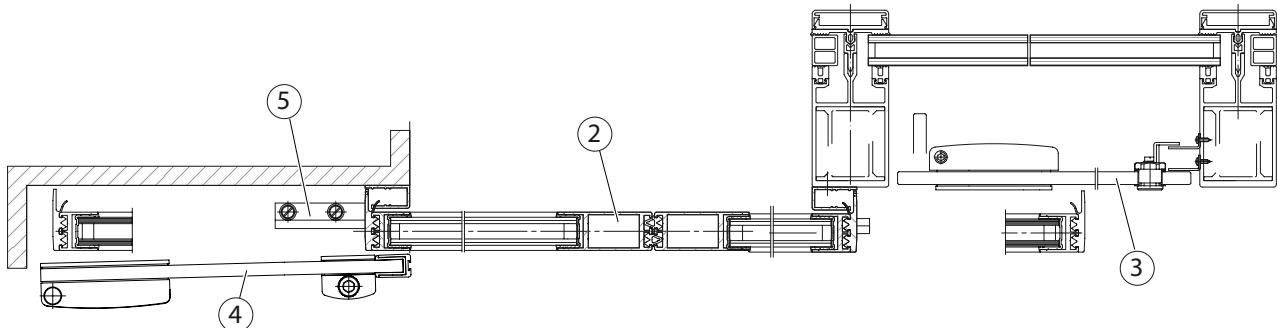

View from the side (Powerdrive with ISO profiles on the wall)

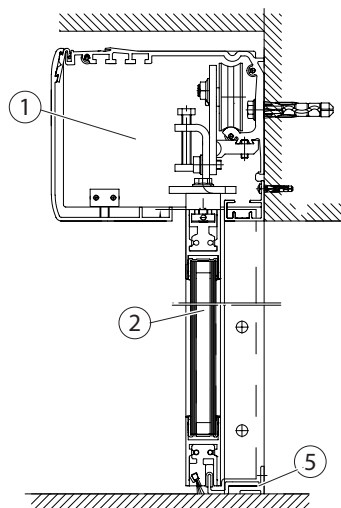

- 1 Drive of the sliding door system
- 2 Moving leaf
- 3 Safety leaf
- 4 Protective leaf
- 5 Floor guide

4 Overview

4.1 Diagrams

Number	Type	Name
70506-0-001	Drive drawing	Powerdrive PL/FR drives
70506-ep01	Installation diagram	Powerdrive PL/FR ISO glass fitting
70506-ep03	Installation diagram	Powerdrive PL/FR toughened safety glass fitting
70506-ep09	Installation diagram	Powerdrive PL/FR wooden leaves
70506-ep10	Installation diagram	Powerdrive PL/PL-FR & hook bolt lock
70506-ep15	Installation diagram	Powerdrive PL/PL-FR ISO & floor lock
70506-ep19	Installation diagram	Powerdrive PL/PL-FR ISO & Lock M
70484-ep04	Installation diagram	Safety leaf for sliding door drives
70715-1-0159	Assembly group drawing	Continuous floor guide
70506-2-0240	Component drawing	Cover version 200×90×6500
70506-2-0238	Component drawing	Cover version 150×90×6500
70506-2-0218	Component drawing	Cover, bespoke 200×105/90
70506-2-0217	Component drawing	Cover, bespoke 150×105/90
70499-2-0247	Component drawing	Track, perforated
70485-2-0200	Component drawing	Track, bespoke PL 2-leaf
70485-2-0251	Component drawing	Track, bespoke PL 1-leaf
70715-9-9872	Installation drawing	ISO leaf lock M aluminium secondary closing edge
70715-9-9873	Installation drawing	ISO leaf lock M rubber secondary closing edge
70715-9-9874	Installation drawing	ISO leaf lock M aluminium secondary closing edge if fixed panel installed under track
70709-9-0994	Installation drawing	Toughened safety glass leaf
70715-9-9850 sheet 1	Installation drawing	ISO leaf aluminium secondary closing edge
70715-9-9850 sheet 2	Installation drawing	ISO leaf rubber secondary closing edge
70715-9-9851 sheet 1	Installation drawing	ISO leaf aluminium secondary closing edge if fixed panel installed under track



The diagrams are subject to change without notice. Use only the most recent version.

4.2 Tools and aids

Tool	Closer size
Tape measure	
Marking pen	
Torque spanner	
Allen key	2 mm, 2.5 mm, 3 mm, 4 mm, 5 mm, 6 mm
Open-ended spanner	8 mm, 10 mm, 13 mm, 15 mm
Screwdriver set	Floor guide slit up to 6 mm, cross-slot PH2 and PZ2
Side-cutting pliers	
Crimping pliers for cables	
Wire stripper	
Multimeter	
Plastic bottle as tip safeguard	
Display programme switch/Service terminal ST220/GEZEconnects	

4.3 Torques

The torques are given at the respective installation step.

4.4 Components and assembly groups

See the ep-drawing for the required installation situation and drive drawings.

5 Installation



WARNING!

Risk of fatal injury due to electric shock!

- ▶ Do not loosen screw-fitted, electrical ground connections.



- ▶ Secure workplace against unauthorised entry.
- ▶ Always work with a second person.
- ▶ Use a stepladder or stepstool with test seal.
- ▶ Keep inside area of track clean.

5.1 Preparations to be made on-site



- ▶ Check the preparations made on site by the customer to ensure proper installation:
 - Type and load capacity of the façade construction or suspending frame
 - Evenness of the installation surface
 - Evenness of the finished floor level
 - Cable plan requirements

5.2 Mounting the track



- ▶ Protect the running surface from damage.

5.2.1 Screw on the track.

View from the side

- ▶ Determine the installation height of the track (2). Take unevenness of wall and floor into account.
 - ▶ Align the track horizontally.
 - ▶ Mark the fastening drill holes (1) (upper row of drill holes on the track).
 - ▶ Remove the track.
 - ▶ Drill the holes (1) for fixing.
 - ▶ Screw the track (2) in place.
 - ▶ Install the sealing profiles (3).
 - ▶ Press rubber seal into the draught sealing profiles.
- With 1-leaf door systems:
- ▶ Install the wall strips (4).

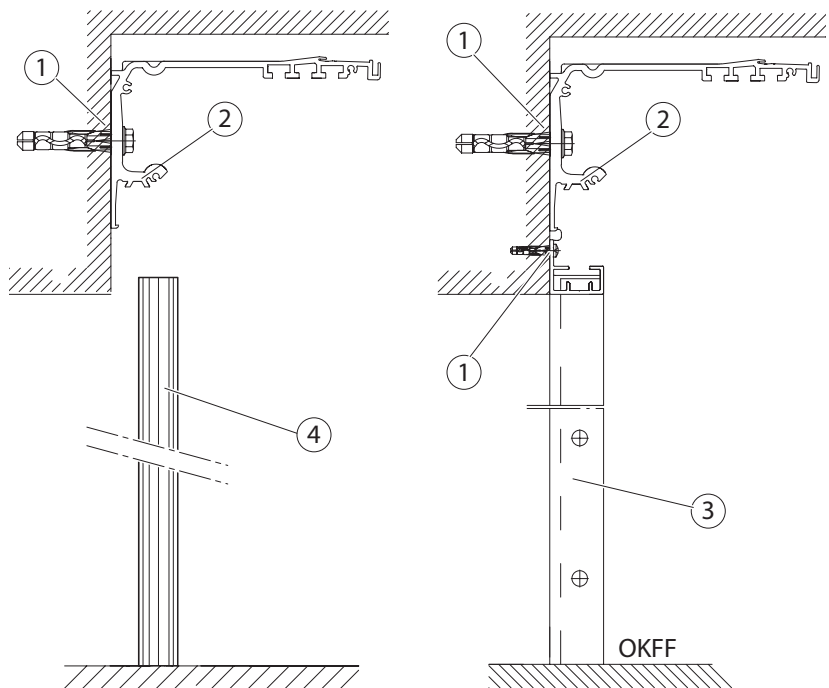

View from above

- 1 Fastening drill holes
- 2 Track
- 3 Sealing profile
- 4 Wall strip
- 5 Protective leaf

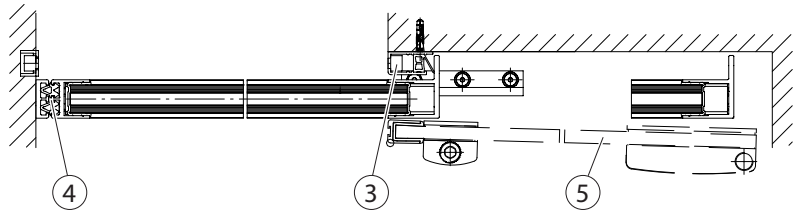

5.3 Mounting the floor guide



- The floor guide is selected based on the on-site conditions. One of the following floor guide options must be used.
- For further information see the respective installation drawing, Chapter 4.1.

5.3.1 Angled floor guide, floor mounting (option)

Angled floor guide with moving leaf left hand slide to open

- ▶ Screw in the angled floor guide (6) with 2 suitable countersunk head screws (1) and (2).

Angled floor guide with moving leaf right hand slide to open

- ▶ Screw in the angled floor guide (6) with 2 suitable countersunk head screws (3) and (2).

- 1 Countersunk screw for moving leaf left hand slide to open
- 2 Countersunk screw
- 3 Countersunk screw for moving leaf right hand slide to open
- 4 outside
- 5 inside
- 6 Angled floor guide

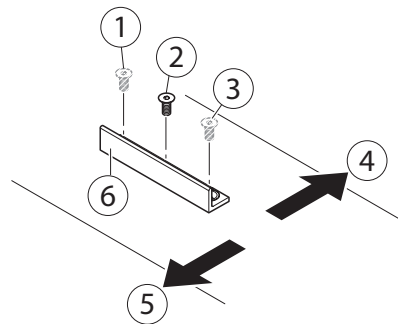

5.3.2 Angled floor guide wall installation (option)

- ▶ Screw the floor guide (3) onto the fixed panel (1) (torque 5 Nm) using two screws (2) if necessary via a spacer plate (4).
- ▶ If there is no fixed panel, mount the floor guide onto the wall using suitable attachment materials.



The spacer plate (4) is available separately.

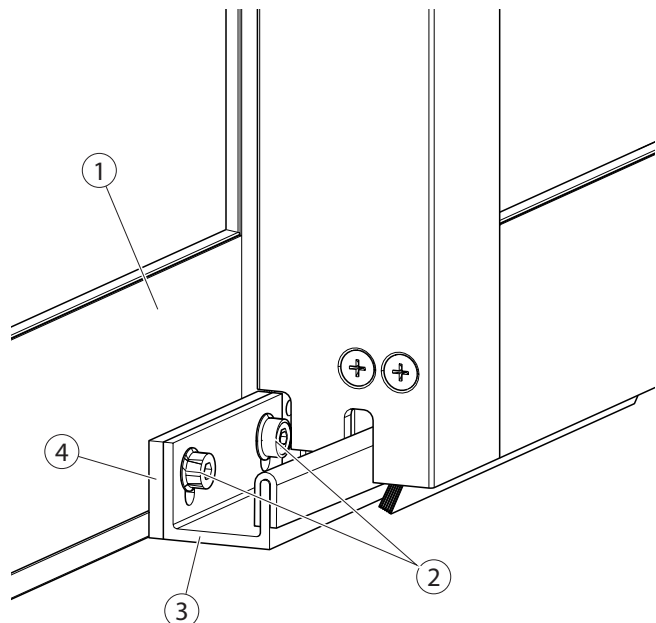

5.3.3 Adjustable angled floor guide wall installation (option)

- ▶ Screw the fastening bracket (2) onto the fixed panel (1) using two screws (6) (tightening torque 10 Nm).
- ▶ Align the moving leaf (4) and thereby the adjusting angle (3).
- ▶ Tighten the screw (5).
- ▶ If there is no fixed panel, mount the floor guide onto the wall using suitable attachment materials.

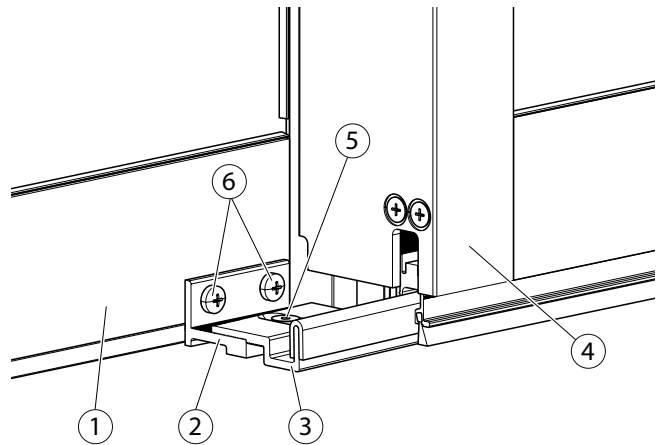

5.3.4 Continuous floor guide (option)



- For assembly of the continuous floor guide, see the "Continuous floor guide" assembly drawing.
- For further information see the respective installation diagrams, Chapter 4.1.

5.4 Installing the moving leaf

5.4.1 Installing the spacer adapters on the moving leaf



- The door suspension plates are installed during glazing of the moving leaves. In case of subsequent installation of the door suspension plates, the frames of the door moving leaves may have to be dismantled.
- ▶ Observe the installation drawings for the moving leaves.



- See installation drawing for the moving leaf for the position of the spacer adapters (1).

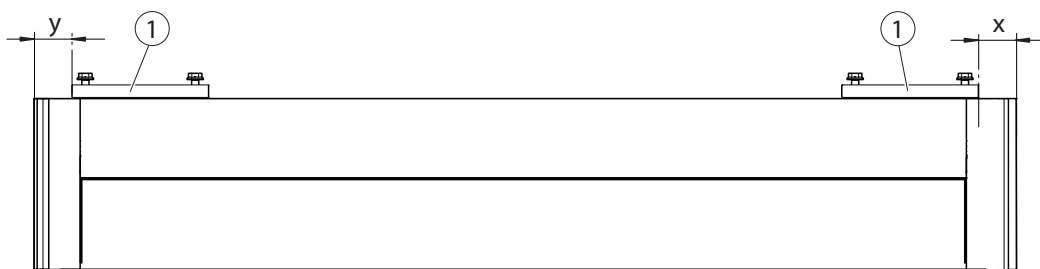

5.4.2 Inserting roller carriage into the track

**CAUTION!****Risk of injury due to a falling roller carriage!**

- ▶ Ensure that the counter-rollers are placed correctly when placing the roller carriage.

- ▶ Swivel the roller carriage (1) into the track from the front.

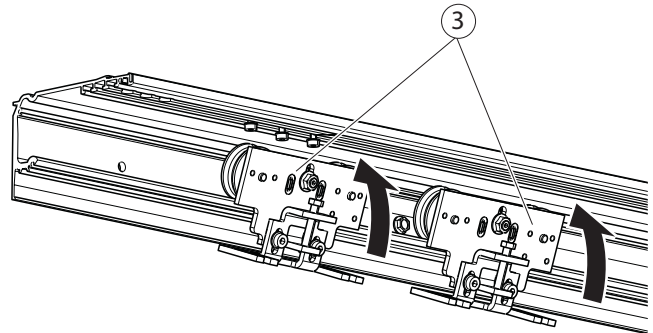

- ▶ Loosen the locknut (3).
- ▶ Slide the counter-roller (2) upwards.
- ▶ Tighten the locknut.

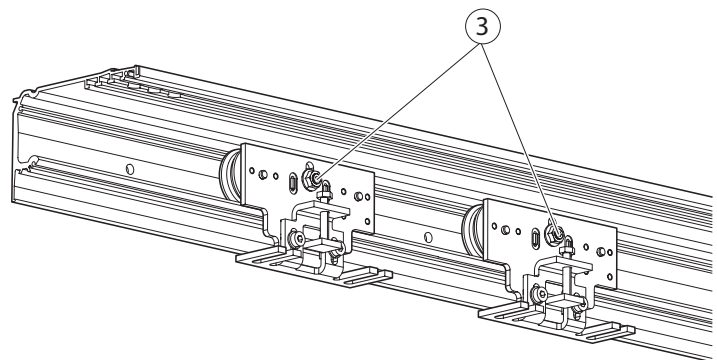

5.4.3 Fitting the moving leaves

**WARNING!**

Risk of injury caused by moving leaf falling over!

The moving leaves are very heavy.

- ▶ At least 2 people should work together to set up the moving leaf.

**WARNING!**

Risk of injury due to glass breakage.

- ▶ At least 2 people should work together to set up the moving leaf.

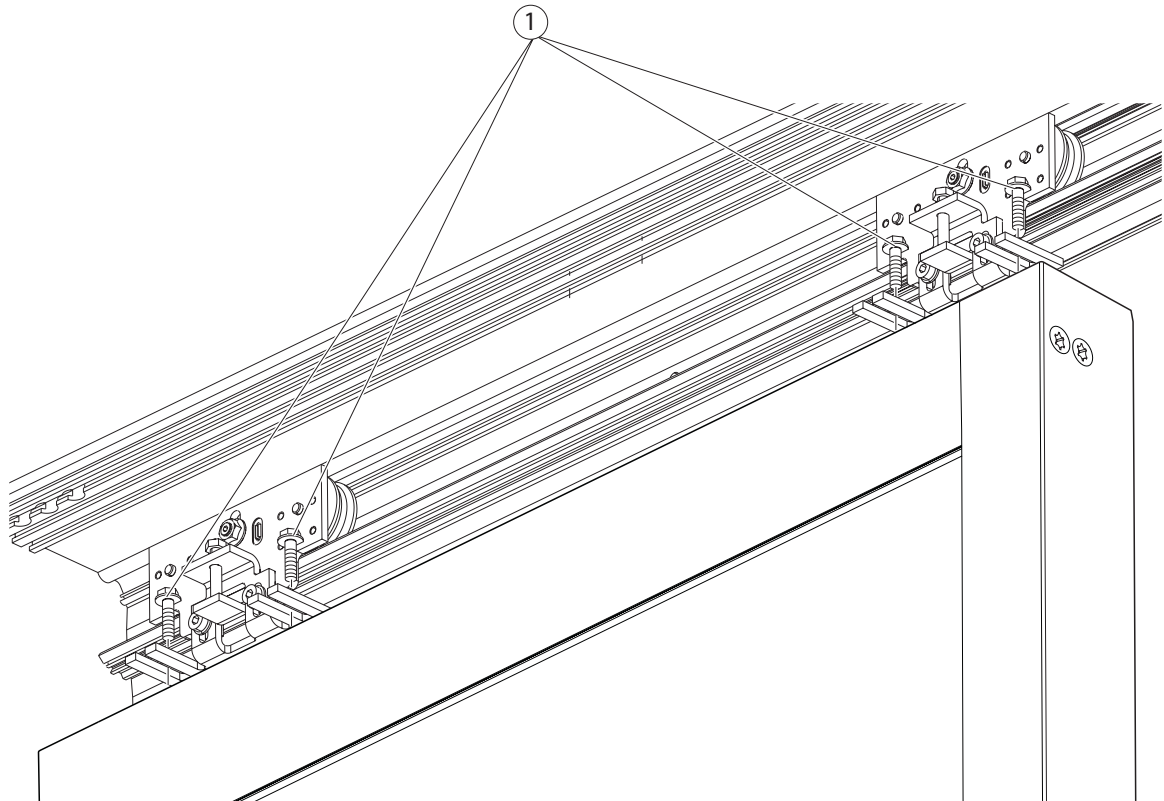

- ▶ Use 4 suspension bolts (1) to screw the moving leaf onto the roller carriage. Tighten the screws slightly.

5.4.4 Adjusting the moving leaves

**WARNING****Risk of crushing!****The moving leaves are still unsecured and move easily.**

- ▶ Ensure that the moving leaves are not moved accidentally or by unauthorised persons!



- ▶ Observe the applicable standards and guidelines on crushing, shearing and drawing-in spots.

- ▶ Loosen the 2 screws (2) on the roller carriage.
- ▶ Adjust the height adjusting screw (1) so that the moving leaves are aligned flush. Ensure the same level and parallel closing edges when doing so.
- ▶ Tighten the 2 screws (2) again (torque approx. 40 Nm).

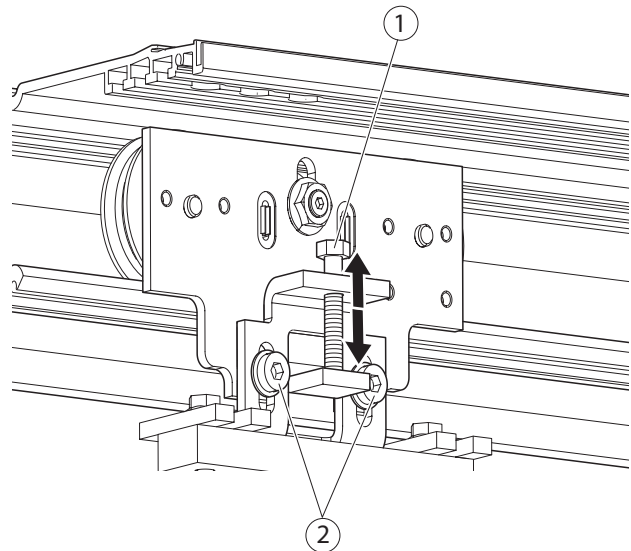

- ▶ Loosen adjustment screws (3).
- ▶ Adjust the position of the moving leaf.
- ▶ Tighten screws (3) (torque 15 Nm) after adjustment.

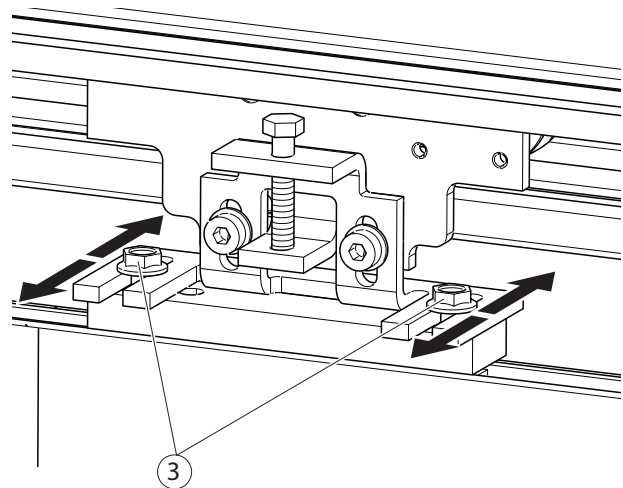

5.4.5 Adjusting the counter-roller

The counter-roller (2) must have a vertical clearance of approx. 0.5 mm to the track (corresponds approximately to the thickness of 4 sheets of copying paper).

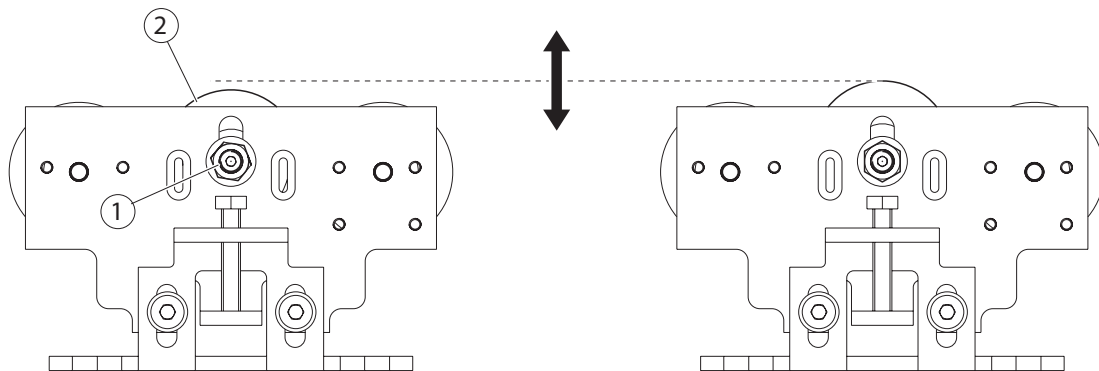
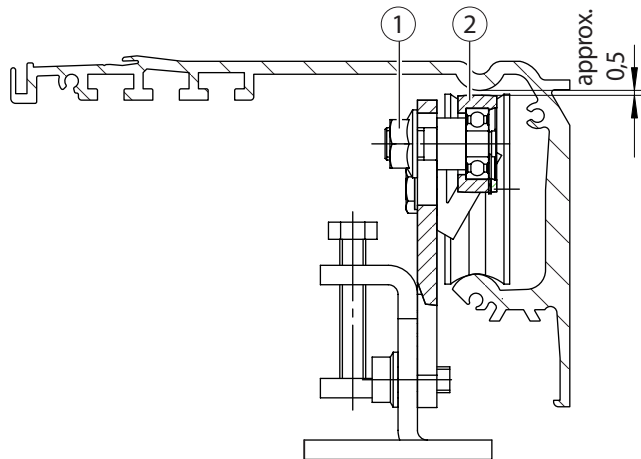

- ▶ Loosen the locknut (1).
- ▶ Move the counter-roller (2) until there is a clearance of approx. 0.5 mm to the track.
- ▶ Re-tighten the locknut (1) (torque 30 Nm).

5.4.6 Installing the driver

- ! Drivers must not touch any obstacle over the entire travel path.
- See the drive drawing for the precise position of the driver.

1-leaf

- i ▶ Mount the driver for 1-leaf door systems in the following positions:
 - right hand slide to open:
Driver position at the bottom on the main closing edge side
 - left hand slide to open:
Driver position at the top on the secondary closing edge side
- Detailed information can be found on the drive drawing.

- ▶ Use 2 screws (1) to fix the driver (2) and the plate (3) to the roller carriage (4) (torque 6 Nm).

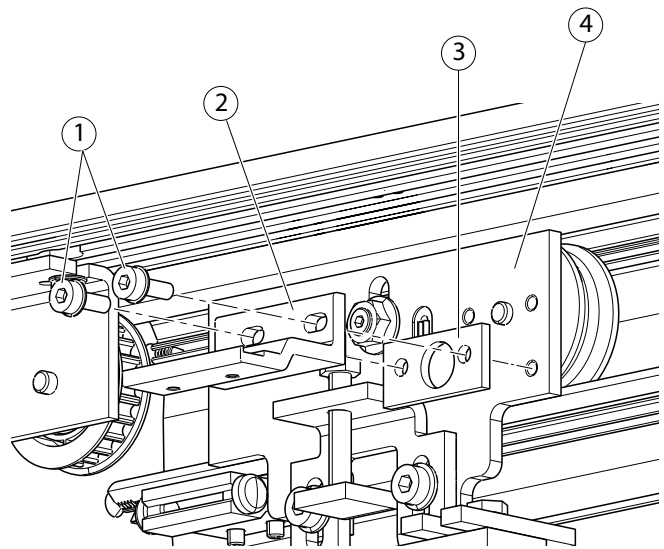

2-leaf

- i ▶ Mount the driver for 2-leaf door systems to the two inner roller carriages. Detailed information can be found on the drive drawing.

- ▶ Use the screws (1) to fix the driver (2) and the plates (3) to the roller carriages (4). Do **not** tighten the screws (1) yet.

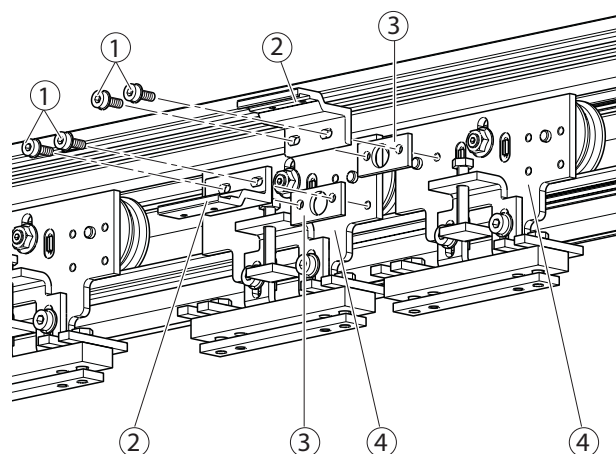

5.5 Mounting the drive components

5.5.1 Fitting the tooth belt

- ▶ Cut the tooth belt to length.
 - ▶ Place the toothed belt on the motor pulley and deflection pulley.
- If there is a toothed belt locking present:
- ▶ Thread the tooth belt into the toothed belt locking.

5.5.2 Fitting the tooth belt to the driver

- ▶ Place the toothed belt locking (1) on the ends of the tooth belt (3) (3 teeth per belt end).

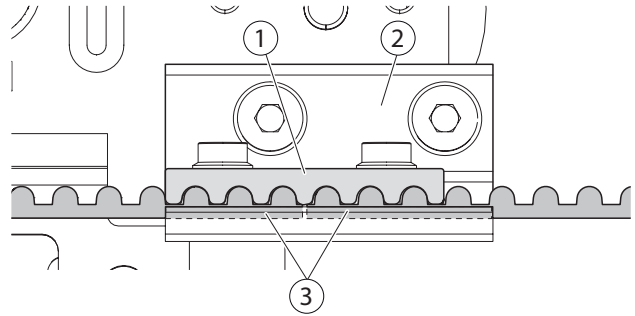

1-leaf

- ▶ Screw the toothed belt locking (1) to the driver (2) using the screws (4) (torque 6 Nm).

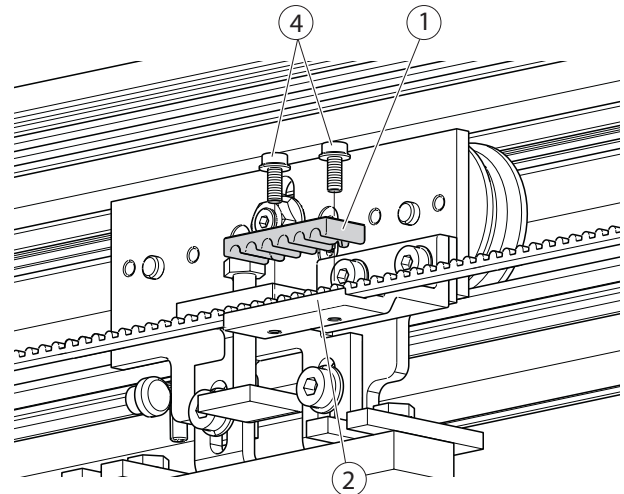

2-leaf

- ▶ Mount both ends of the tooth belt (3) using the toothed belt locking (1) on the driver (2) using screws (4) (torque 6 Nm).

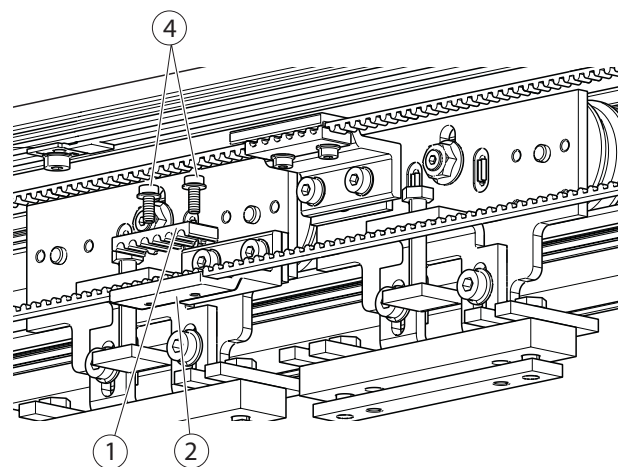

The second toothed belt locking is installed only after adjusting the closing position.

5.5.3 Tensioning the tooth belt

- ! ▶ The tooth belt must be pre-tensioned with $300\text{ N} \pm 35\text{ N}$ (see drive drawing).

- ▶ Undo 2 screws (2).
- ▶ Slide the motor gear unit (3) to the right by hand.
- ▶ Undo the screw (1) and move the sliding block in such a way that a slot-head screwdriver can be pushed between the sliding block and the motor gear unit.
- ▶ Tighten the screw (1) (torque 10 Nm).
- ▶ Push the slot-head screwdriver into the gap and lever it until the tooth belt is pre-tensioned.
- ▶ Tighten 2 screws (2) (torque 15 Nm).

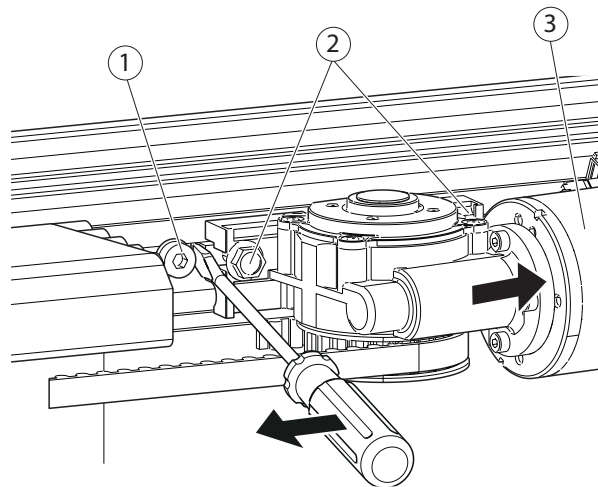

5.5.4 Setting the closing position

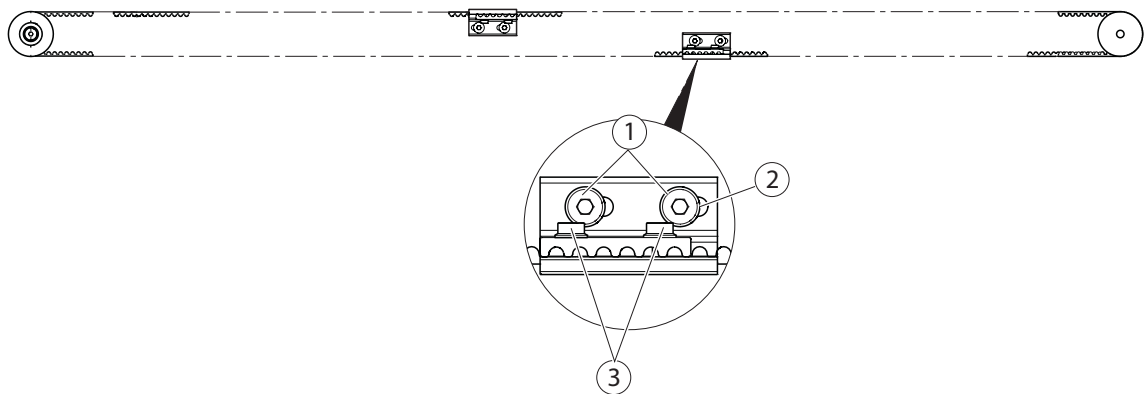

For 2-leaf door systems:

- ▶ Slide the moving leaf to the closed position.
- ▶ Mount the second belt lock with screws (3) on the driver (torque 6 Nm).
- ▶ Use the oblong holes (2) to finely adjust the position in the direction of displacement.
- ▶ Tighten the screws (1) on both belt locks when the exact closing position has been set (torque 6 Nm).

5.5.5 Setting the stop buffer

- ▶ Undo the setscrews (2) on the stop buffer (1).
- ▶ Slide the moving leaf to the open position.
- ▶ Slide the stop buffer on the roller carriages.
- ▶ Tighten the setscrews (2) using the Allen key (torque 3 Nm).

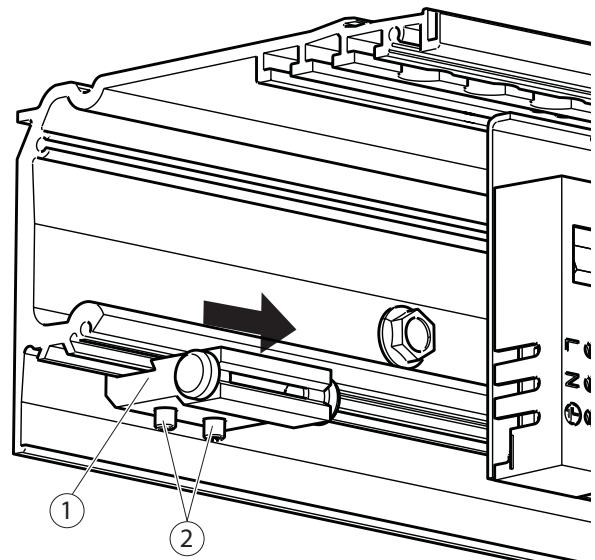

5.5.6 Positioning the tooth belt locking mechanism (optional)

- ▶ Close the moving leaves.
- ▶ Loosen the screws (1) at the tooth belt locking mechanism (optional).
- ▶ Align the locking device.

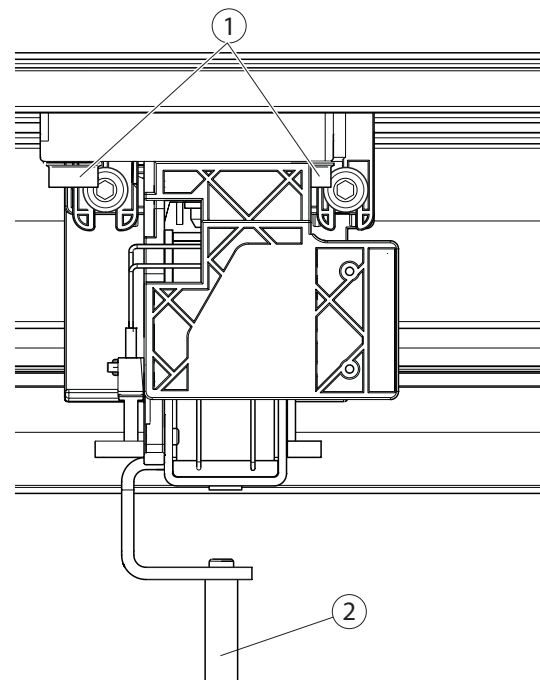

Following installation the locking pin (2) must be positioned in the hole in the cover so that the locking mechanism can be locked and unlocked.

- ▶ If necessary enlarge the drill hole.
- ▶ Tighten screws (1).
- ▶ Adjust the locking guide (3) so that the tooth belt neither touches nor has too much clearance. To do so, loosen 2 screws (4), move the locking guide (3) and re-tighten the flathead screws (4) (torque 5 Nm).

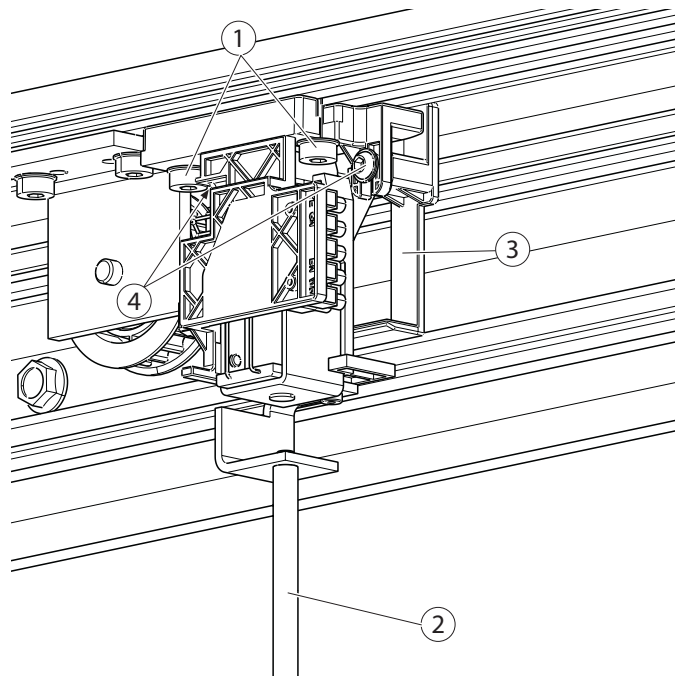

! The driver must not come into contact with the tooth belt locking mechanism (optional) during operation.

! ▶ After the tooth belt has been installed, check (click) the switching points of the indicator switches of the tooth belt locking mechanism (optional). Adjust by bending the actuator levers, if necessary.

5.6 Installing cable guides

- ! **Cables can be cut!**
- ▶ Lay cables in such a way that there are no cables near the moving parts.
Cable guide spacing approx. 200 mm.

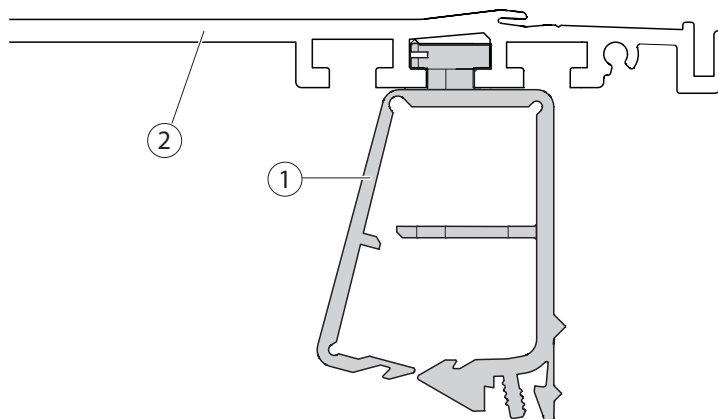

- ▶ Fix the cable guide (1) on the track (2).

5.7 Connecting the tooth belt locking mechanism (optional) and control unit

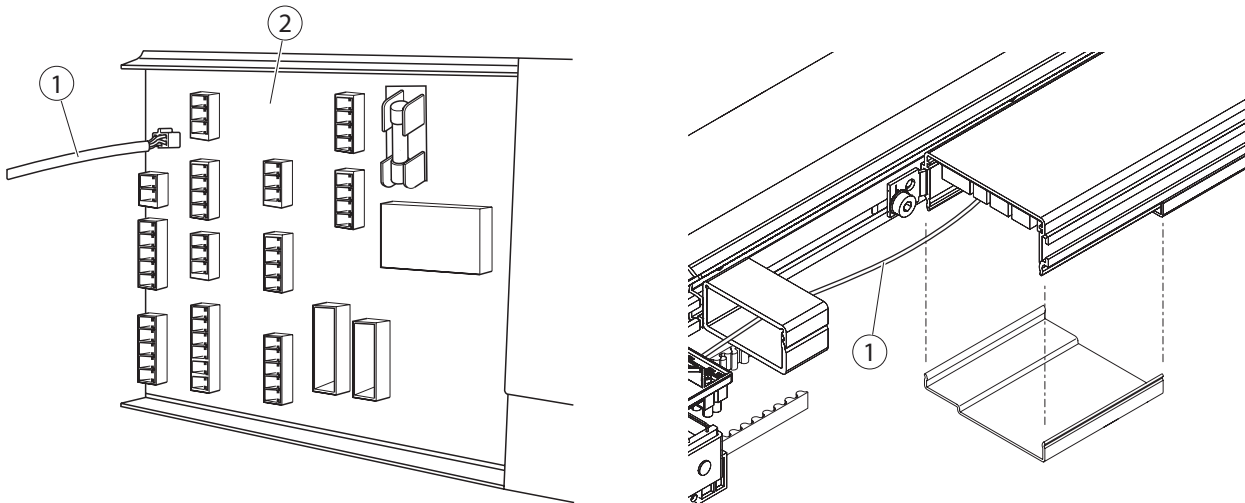

- ▶ Plug the cable tooth belt locking mechanism (optional) (1) in at the control unit (2).
- ▶ Route the cable to the tooth belt locking mechanism (optional).

5.8 Connecting the transformer ground

- ! The track is not earthed if there is a poor connection between earthing jumper (3) and track.
- ▶ Check whether the setscrews (4) of the earthing jumper (3) penetrate the anodised layer of the track.

- ▶ Connect the earthing cable (2) from the transformer to the device flat plug (1).

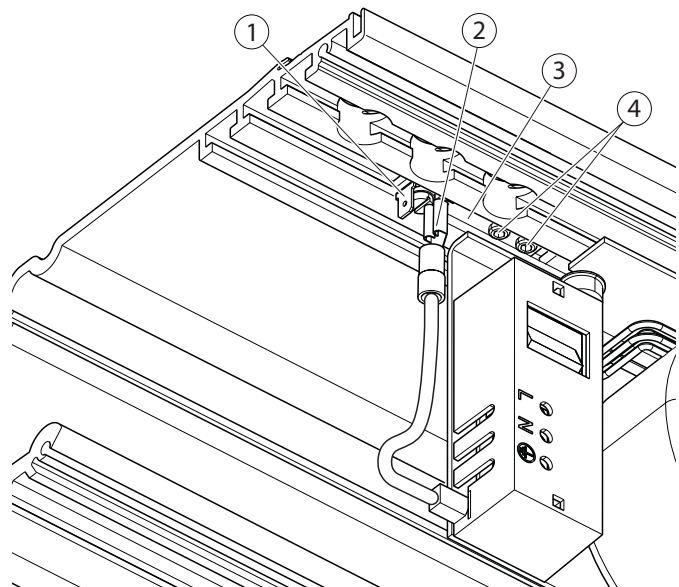

6 Production test and commissioning

6.1 Connecting the drive



WARNING

Risk of fatal injury due to electric shock!

- ▶ The electrical system (230 V) may only be connected and disconnected by a professional electrician or specialist electrical technician.
 - ▶ Carry out mains connection and earth conductor test in accordance with VDE 0100 Part 600.
-
- ▶ Remove the sheath of the mains cable (4) on a max. of 40 mm.

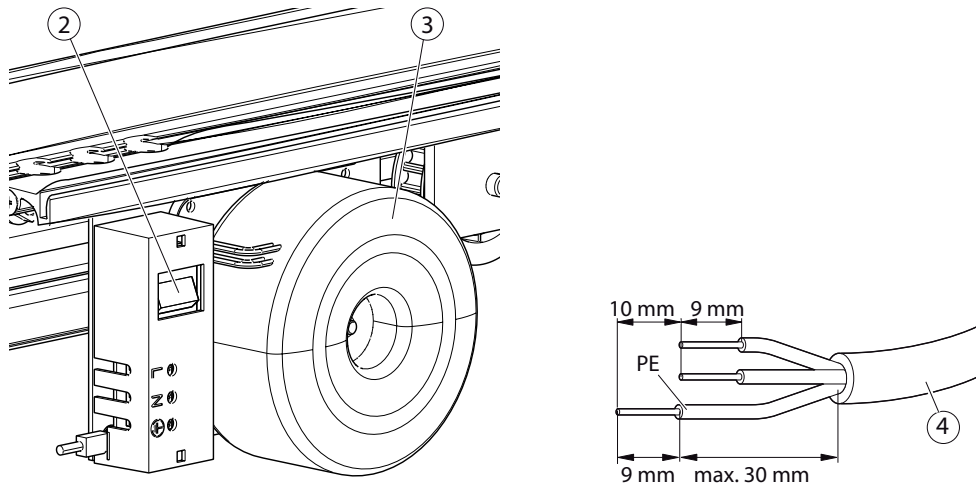

- ▶ Strip the mains cable (4).
 - Sheath removal length 40 mm
 - Stripping length 9 mm
 - PE line lead 10 mm
- ▶ Connect the drive to the 230 V mains network.
- ▶ Switch on the main switch (2) on the transformer (3).
- ▶ Insert the rechargeable battery connector (1) at the control unit.

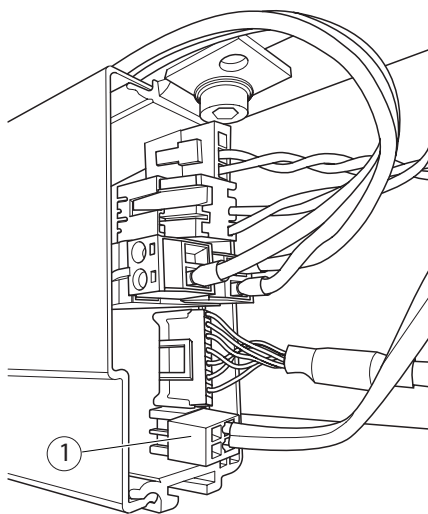

- ▶ Carry out the production test as described in the wiring diagram "Automatic sliding doors DCU1-NT/DCU1-2M-NT".

6.2 Mounting the cover



WARNING!

Risk of injury!

People can be injured when the cover is handled.

- ▶ Always make sure two people handle the cover.



WARNING!

Risk of injury from falling cover!

▶ Make sure that the cover is attached along the entire length of the track.

▶ Release the cover carefully and check whether it has been suspended safely.

- ▶ Unscrew the locking pin (1) from the tooth belt locking mechanism (optional).

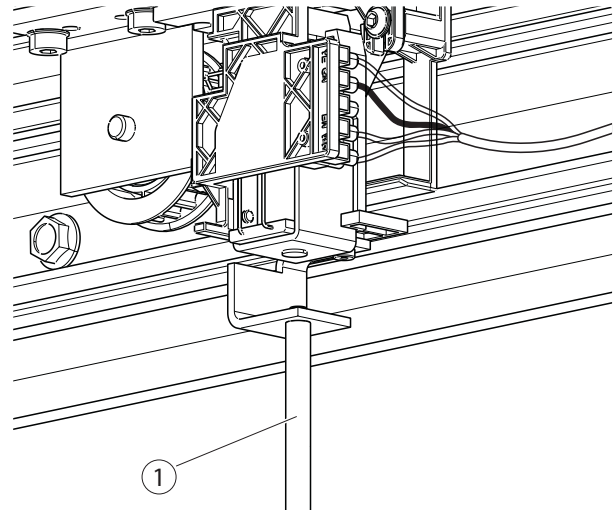

6.2.1 Mounting the cover fixing

- Regardless of the drive length, one cover fixing (1) must be mounted on each end of the cover, as well as another fixing offset by 100 mm.
- Up to a 3000 mm drive length, a total of seven cover fixings must be mounted.
- Above a 3000 mm drive length, a total of 10 cover fixings must be mounted.

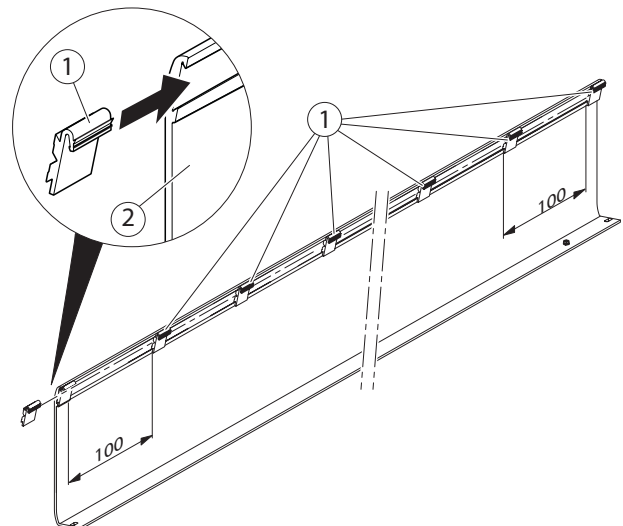

6.2.2 Attaching the cover

- ▶ Hook the cover (2) with cover fixing (1) on the track (3).

! The cover may not be swiveled up by more than 90° during opening. See Chapter 7.1.1 on how to remove the cover.

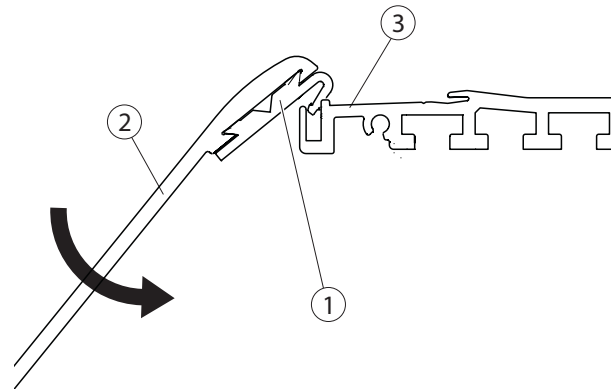

- ▶ Swivel the cover downwards and turn it into the threaded pin (4).

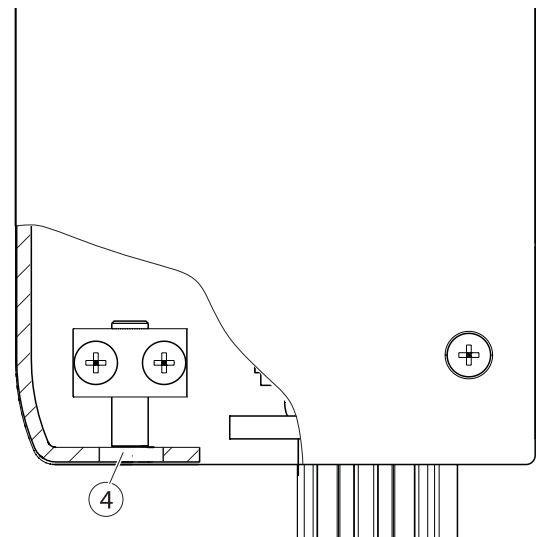

- ▶ Place the leaf springs (5) over the cover fixings (1) on the outside: place one leaf spring at each of the outermost of the two cover fixings.

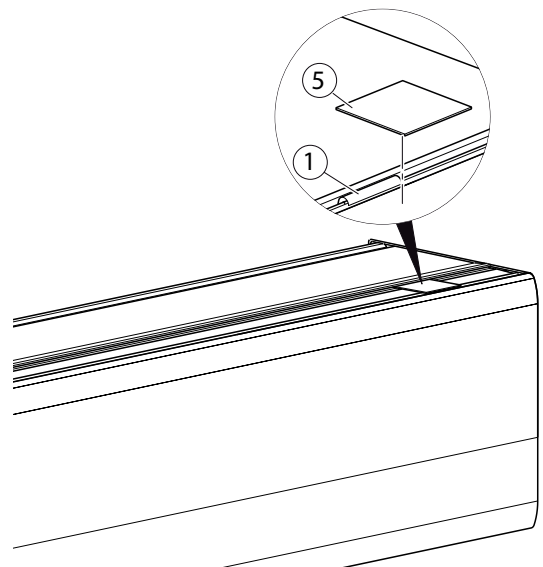

- ▶ Screw the locking pin for toothed belt locking (option) in again.

6.2.3 Connecting cover earthing

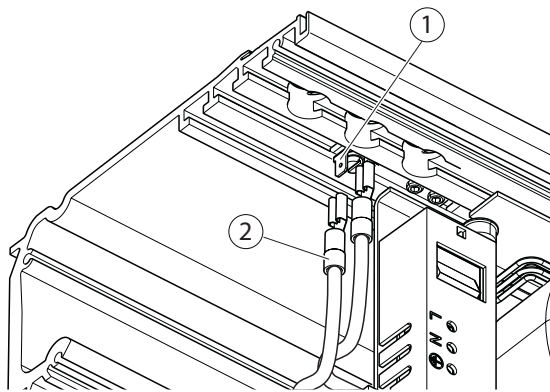

- ▶ Connect the earthing cable (2) of the cover with the second plug-in connection of the device flat plug (1).

6.3 Mounting the safety devices



For information about connection and parameter setting of the safety sensors, and the inputs and outputs and on commissioning, please refer to the wiring diagram.

- ▶ Mount safety and activation equipment.
 - ▶ Route cables properly in cable ducts.
- For electrical installation, see wiring diagram.

6.4 Installing operating elements/switches/push buttons

For electrical installation, see wiring diagram.



- ▶ Mount the operating elements so that users cannot stand in the danger zones.

6.5 Commissioning the door system



For information about connection and parameter setting of the safety sensors, and the inputs and outputs and on commissioning, please refer to the wiring diagram.

6.5.1 Creating the log book

- ▶ Carry out a safety analysis.
- ▶ Record installed options in the safety analysis for the operator.

6.6 Dismantling



WARNING!

Risk of injury!

People can be injured when the cover is handled.

- ▶ Always make sure two people handle the cover.



CAUTION!

Risk of injury due to impact and crushing!

- ▶ Secure the moving leaves against unintentional movement.
- ▶ Disconnect the rechargeable battery.

Dismantling is done in the reverse order of installation.

7 Service and maintenance

7.1 Mechanical service

7.1.1 Removing the cover



Before opening the cover each time, check the following:

- Are the leaf springs and cover fixings fitted correctly (see Chapters 6.2.1 and 6.2.2)?
- Are the cover fixings in good condition, based on a visual inspection (see also Chapter 7.2)?

The cover can be opened upwards to a maximum of 90° for minor maintenance tasks.

For larger maintenance tasks, remove the cover.

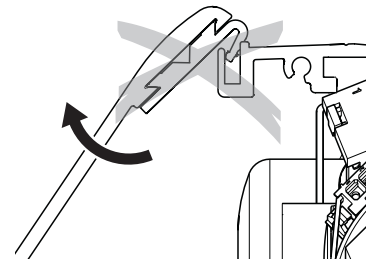

- ▶ Remove the leaf springs (5, Chapter 6.2.2) via the cover fixings.
- ▶ Loosen the threaded pins (cover catch) (4, Chapter 6.2.2) and swivel the cover up until it can be removed.
- ▶ Press the cover upwards out of the track.
- ▶ Disconnect the ground cable and sensors.
- ▶ Place the cover securely on the track or floor.



- ▶ Protect the visible surface against scratches using suitable means.

7.1.2 Checking tooth belt tension

- ▶ Put the door into operation.
The tooth belt must not lift up from the motor gear or skip when braking and accelerating.
- ▶ If the tooth belt lifts up or jumps, adjust the tooth belt tension to $300 \text{ N} \pm 35 \text{ N}$.

7.1.3 Tensioning the tooth belt

See chapter 5.5.3.

7.2 Maintenance



CAUTION!

Risk of injury due to impact and crushing!

- ▶ Secure door leaves against accidental movement.
- ▶ Disconnect rechargeable battery.
- ▶ Disconnect the mains voltage.



- Only original replacement parts may be used.
- To ensure proper function, the wear parts of the sliding door system must be inspected and exchanged if necessary during every maintenance.



- The prescribed maintenance work on the sliding door system must be handled by an expert:
 - at least once a year
 - or
 - When the service indicator on the programme switch lights up (see wiring diagram).
- Not all wear parts listed may be present, depending on the configuration.
- ▶ Provide test documents and keep them up-to-date.

Wear parts present	Exchange interval
Rechargeable battery	Two years
Roller carriage track and support rollers	In case of wear or damage
Cleaning and sealing brushes	In case of wear or damage
Tooth belt	In case of wear or damage
Floor guide	In case of wear or damage
Deflection pulleys	In case of wear or damage
Motor gear unit	In case of wear or damage
Cover fixing	In case of wear or damage
Rubber cable	In case of wear or damage
Pulleys for rubber cable	In case of wear or damage



After completing the maintenance work, always execute the learning function for the door.

Tested component	Action	Comments
Track	Check for cracks	▶ Replace the track
	Check for cleanliness	▶ Clean the track
Roller carriage	Check the abrasion of the track rollers	▶ Remove the abrasion
	Check brushes	▶ Remove roller carriage. ▶ Replace the brushes if necessary (see Chapter 8.1.4)
Floor guide area	Check for jarring-free function	▶ Clean floor guide area
Floor guide area (brushes)	Check for contamination and hardness	▶ Clean or replace
Moving leaf	Check for smooth movement	▶ See Chapter 8.1.1
Tooth belt	Check for wear & tear and damage	▶ If necessary, replace the tooth belt(see Chapter 5.5.1)
	Check tension	▶ If necessary, tighten the tooth belt (see Chapter 5.5.6)
	Check tooth belt locking mechanism (optional) for damage	▶ Re-position the tooth belt locking mechanism (optional) if necessary (see Chapter 5.5.6)
Tooth belt locking mechanism (optional)	Check function	▶ Re-position the tooth belt locking mechanism (optional) (see Chapter 5.5.6)
Screws	Check for tight fit	▶ Tighten the screws if (refer to drive drawing for torques)
Assembly groups and peripherals	Check for correct function	▶ Replace assembly group
Cables	Check for damage and correct fastening	▶ Fasten or replace cables
Cover fixing	Check for cracks and fading	▶ Replace cover fixing. Document replacement of the cover fixing
	Check for damage e.g. brittle plastic	
	Check whether one year or more has passed since the last maintenance	

8 Troubleshooting

8.1 Mechanical faults

Cause	Remedy
Track bent	<ul style="list-style-type: none"> ▶ Replace the track ▶ Check the installation surface
Moving leaf stiff	<ul style="list-style-type: none"> ▶ Check the moving leaf (see Chapter 8.1.1)
Roller carriage jammed or defective, high abrasion on the track rollers	<ul style="list-style-type: none"> ▶ Replace the track roller (see Chapter 8.1.3), clean the track
Tooth belt damaged	<ul style="list-style-type: none"> ▶ Replace the tooth belt
Cover fixing faulty	<ul style="list-style-type: none"> ▶ Replace cover fixing (see Chapter 6.2.1).

8.1.1 Checking moving leaf

- ▶ Disconnect the moving leaf from the toothed belt using the toothed belt locking.
- ▶ Move the moving leaf and check for ease of movement.

If moving leaves move easily:

- ▶ Check the motor gear unit and deflection pulley and replace if necessary.

8.1.2 Replacing roller carriage

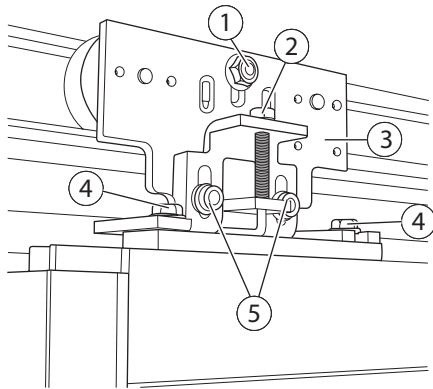

- ▶ Secure moving leaf against falling.
- ▶ Separate driver from roller carriage (3) if necessary.
- ▶ Loosen nut (1) of the counter roller and slide the counter roller downwards.
- ▶ Loosen the 2 screws (5) and lower the moving leaf using the height adjusting screw (2) until it touches the ground.
- ▶ Screw the 2 screws (5) out completely.
- ▶ Tilt the moving leaf carefully until the roller carriage can be accessed freely.
- ▶ Screw the 2 screws (4) off.
- ▶ Replace the roller carriage (3) and screw tight using the screws (4). Note the distance to the wall.
- ▶ Align the moving leaf again in vertical and horizontal position.
- ▶ Screw the 2 screws (5) in, but do not tighten them yet.
- ▶ Use the height adjusting screw (2) to set the moving leaf to the correct height.
- ▶ Tighten the 2 screws (5) with approx. 40 Nm.
- ▶ Adjust the counter roller (see Chapter 5.4.5).

8.1.3 Replacing track rollers

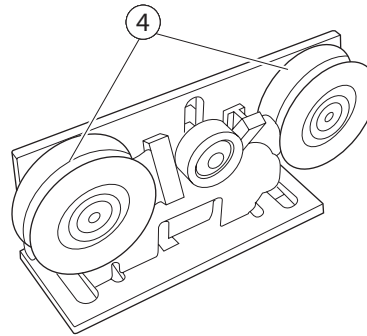
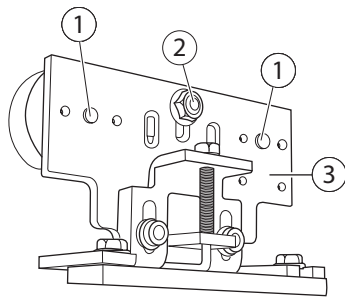

- ▶ Remove the roller carriage (3), see Chapter 8.1.2.
- ▶ Screw the pivots (1) of the track rollers off.
- ▶ Screw the screw (2) off.
- ▶ Exchange the track roller (4) (torque 20 Nm).
- ▶ Reinstall roller carriage in reverse order.

8.1.4 Replacing brushes

- ▶ Secure moving leaf against falling.
- ▶ Unhook the moving leaf if necessary and tilt it as described in Chapter 8.1.2.
- ▶ Pull brushes (3) out of pulley holder (1).
- ▶ Clean rollers (2) and insert new brushes.
- ▶ Hook the moving leaf in again and adjust it.
- ▶ Adjust the counter roller (see Chapter 5.4.5).

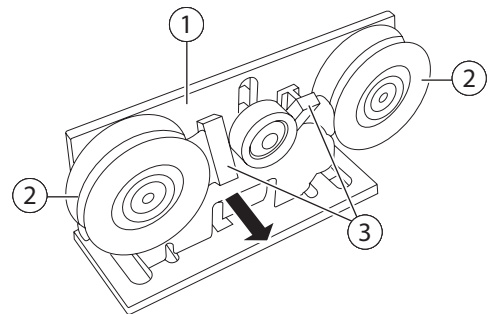

8.2 Electrical faults

- ▶ For read-out instructions and a list of fault messages, see wiring diagram.

8.2.1 Replacing fuse in transformer



DANGER!

Risk of fatal injury due to electric shock!

If the main switch on the transformer is activated, the fuse is still energised since it is upstream of the main switch.

The mains voltage 230/115 V must be disconnected from the mains upstream of the fuse.

- ▶ Disconnect the door system from the 230/115 V mains supply on site before removing the PCB cover (1) and secure against being switched back on again.



- ▶ You will find the fuse value on the wiring diagram.

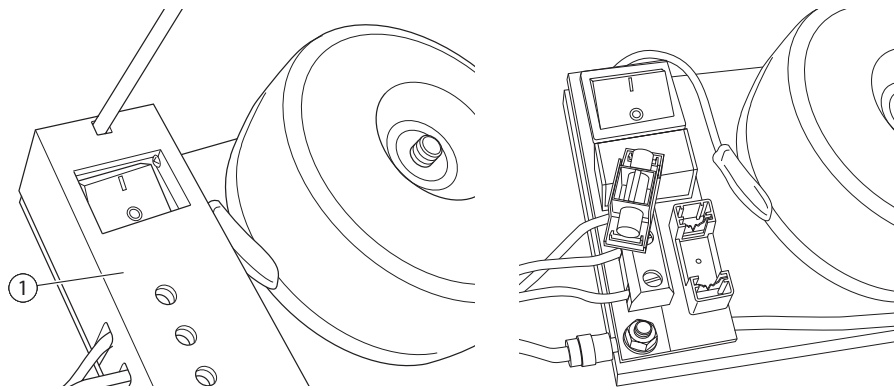

- ▶ Insert a suitable screwdriver into the opening of the PCB cover (1) above the switch.
- ▶ Carefully press the end wall of the PCB cover upward with the tip of the screwdriver. This releases the snap catch.
- ▶ Remove the PCB cover (1).
- ▶ Pull the fuse holder forwards and off and replace the defective fuse.
- ▶ Attach the fuse holder.



- ▶ Do not trap the cable when setting the cover in place.

- ▶ Set the PCB cover (1) in place and clip on.

9 Drive type plate



Only relevant in Germany and within the scope of validity of DIN 18650-1.

► Add the classification code to the type plate.

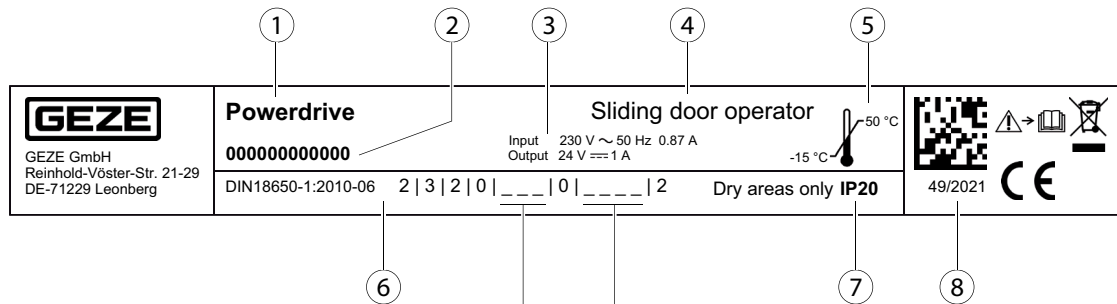

Safety devices on the drive (fifth character)

A distinction is made between three classes in terms of safety requirements:

- 1: Force limitation;
- 2: Connection to external safety systems which have been approved by the drive manufacturer;
- 3: Low-energy.

Note: Several classes may be marked.

Safety for automatic door systems – version/ installation (seventh character)

A distinction is made between five classes of safety devices on door leaves:

- 0: No safety devices;
- 1: With sufficiently dimensioned safety distances
- 2: With protection against crushing, shearing and drawing-in of fingers;
- 3: With built-in turning fitting unit;
- 4: With sensor-controlled protective devices.

Note: Several classes may be marked.

- 1 Product name
- 2 Serial number
- 3 Electr. data
- 4 Machine category
- 5 Ambient temperature
- 6 Only relevant in Germany and within the scope of validity of DIN 18650-1: Classification code
- 7 IP rating
- 8 Date of manufacture

10 Inspection of the installed door system

10.1 Measures to prevent and secure hazardous areas

- ▶ Check protective earth connection to all metal parts that can be touched.
- ▶ Perform a safety analysis (risk analysis).
- ▶ Check the function of safety sensors and movement detectors.

10.2 Assembly check list Powerdrive product family

no.	Test	in	On page	Completed
1	All cables routed correctly for installation of the Powerdrive?	–	–	
2	Track mounted?	5.2	8	
3	Angled floor guide mounted?			
	▫ Angled floor guide, floor mounting (option)	5.3.1	9	
	▫ Angled floor guide wall installation (option)	5.3.3	10	
4	Continuous floor guide mounted (option)?	5.3.4	10	
5	Moving leaf installed?	5.4	10	
6	Drive components installed?	5.5	16	
7	Tooth belt mounted?	5.5.1	16	
8	Tooth belt locking mechanism (optional) and control unit connected?	5.7	20	
9	Safety devices mounted?	6.3	24	
10	Switches/push buttons installed and correctly connected?	6.4	24	
11	Programme switch installed?	6.4	24	
12	Transformer ground fitted?	5.8	20	
13	230/115 V connection established?	6.1	21	
14	Cover earthing connected?	6.2.3	24	
15	Cover fixing mounted?	6.2.1	22	
16	Safety analysis carried out?	–	–	
17	Deviations of the door system checked in accordance with safety analysis?	–	–	
18	Are all components mounted in accordance with the following instructions:	–	–	
19	▫ Pre-installation instructions for the Powerdrive product family	–	–	
20	▫ Installation instructions Powerdrive – girder section and side panel	–	–	
21	▫ Pre-installation instructions profile system leaves and side panel	–	–	
22	▫ Installation instructions protective leaf for sliding door drives	–	–	
23	▫ Installation instructions safety leaf	–	–	
24	Type plate added to the drive?	9	30	
	Notes:			
	▫ Only relevant for Germany and within the scope of validity of DIN 18650-1.			
	▫ The type plate may only be attached to the drive if assembly was also checked for correct completion according to the GEZE specifications using the check list.			

Germany
GEZE GmbH
Niederlassung Süd-West
Tel. +49 (0) 7152 203 594
E-Mail: leonberg.de@geze.com

GEZE GmbH
Niederlassung Süd-Ost
Tel. +49 (0) 7152 203 6440
E-Mail: muenchen.de@geze.com

GEZE GmbH
Niederlassung Ost
Tel. +49 (0) 7152 203 6840
E-Mail: berlin.de@geze.com

GEZE GmbH
Niederlassung Mitte/Luxemburg
Tel. +49 (0) 7152 203 6888
E-Mail: frankfurt.de@geze.com

GEZE GmbH
Niederlassung West
Tel. +49 (0) 7152 203 6770
E-Mail: duesseldorf.de@geze.com

GEZE GmbH
Niederlassung Nord
Tel. +49 (0) 7152 203 6600
E-Mail: hamburg.de@geze.com

GEZE Service GmbH
Tel. +49 (0) 1802 923392
E-Mail: service-info.de@geze.com

Austria
GEZE Austria
E-Mail: austria.at@geze.com
www.geze.at

Baltic States –
Lithuania / Latvia / Estonia
E-Mail: baltic-states@geze.com

Benelux
GEZE Benelux B.V.
E-Mail: benelux.nl@geze.com
www.geze.be
www.geze.nl

Bulgaria
GEZE Bulgaria - Trade
E-Mail: office-bulgaria@geze.com
www.geze.bg

China
GEZE Industries (Tianjin) Co., Ltd.
E-Mail: chinasales@geze.com.cn
www.geze.com.cn

GEZE Industries (Tianjin) Co., Ltd.
Branch Office Shanghai
E-Mail: chinasales@geze.com.cn
www.geze.com.cn

GEZE Industries (Tianjin) Co., Ltd.
Branch Office Guangzhou
E-Mail: chinasales@geze.com.cn
www.geze.com.cn

GEZE Industries (Tianjin) Co., Ltd.
Branch Office Beijing
E-Mail: chinasales@geze.com.cn
www.geze.com.cn

France
GEZE France S.A.R.L.
E-Mail: france.fr@geze.com
www.geze.fr

Hungary
GEZE Hungary Kft.
E-Mail: office-hungary@geze.com
www.geze.hu

Iberia
GEZE Iberia S.R.L.
E-Mail: info.es@geze.com
www.geze.es

India
GEZE India Private Ltd.
E-Mail: office-india@geze.com
www.geze.in

Italy
GEZE Italia S.r.l. Unipersonale
E-Mail: italia.it@geze.com
www.geze.it

GEZE Engineering Roma S.r.l
E-Mail: italia.it@geze.com
www.geze.it

Korea
GEZE Korea Ltd.
E-Mail: info.kr@geze.com
www.geze.com

Poland
GEZE Polska Sp.z o.o.
E-Mail: geze.pl@geze.com
www.geze.pl

Romania
GEZE Romania S.R.L.
E-Mail: office-romania@geze.com
www.geze.ro

Russia
OOO GEZE RUS
E-Mail: office-russia@geze.com
www.geze.ru

Scandinavia – Sweden
GEZE Scandinavia AB
E-Mail: sverige.se@geze.com
www.geze.se

Scandinavia – Norway
GEZE Scandinavia AB avd. Norge
E-Mail: norge.se@geze.com
www.geze.no

Scandinavia – Denmark
GEZE Danmark
E-Mail: danmark.se@geze.com
www.geze.dk

Singapore
GEZE (Asia Pacific) Pte, Ltd.
E-Mail: gezesea@geze.com.sg
www.geze.com

South Africa
GEZE South Africa (Pty) Ltd.
E-Mail: info@gezesa.co.za
www.geze.co.za

Switzerland
GEZE Schweiz AG
E-Mail: schweiz.ch@geze.com
www.geze.ch

Turkey
GEZE Kapı ve Pencere Sistemleri
E-Mail: office-turkey@geze.com
www.geze.com

Ukraine
LLC GEZE Ukraine
E-Mail: office-ukraine@geze.com
www.geze.ua

United Arab Emirates/GCC
GEZE Middle East
E-Mail: gezeme@geze.com
www.geze.ae

United Kingdom
GEZE UK Ltd.
E-Mail: info.uk@geze.com
www.geze.com

GEZE GmbH
Reinhold-Vöster-Straße 21–29
71229 Leonberg
Germany

Tel.: 0049 7152 203 0
Fax.: 0049 7152 203 310
www.geze.com

